

INSTRUCTION MANUAL

CMOS COLOR CAMERA

IK-HR1S

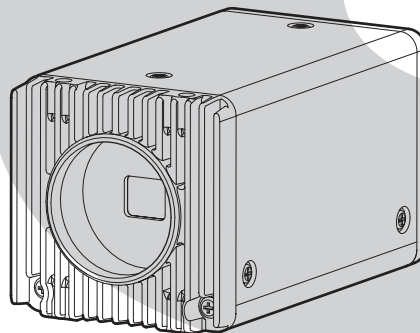

IK-HR1S

The above model is classified as a green product (*1), as indicated by the letter marking (G) after model name. This Service Manual describes replacement parts for the green product. When repairing this green product, use the part(s) described in this manual and lead-free solder (*2).

For (*1) and (*2), see the next page.

(*1)

GREEN PRODUCT PROCUREMENT

The EC is actively promoting the WEEE & RoHS Directives that define standards for recycling and reuse of Waste Electrical and Electronic Equipment and for the Restriction of the use of certain Hazardous Substances. From July 1, 2006, the RoHS Directive will prohibit any marketing of new products containing the restricted substances.

Increasing attention is given to issues related to the global environmental. Toshiba Corporation recognizes environmental protection as a key management tasks, and is doing its utmost to enhance and improve the quality and scope of its environmental activities. In line with this, Toshiba proactively promotes Green Procurement, and seeks to purchase and use products, parts and materials that have low environmental impacts.

Green procurement of parts is not only confined to manufacture. The same green parts used in manufacture must also be used as replacement parts.

(*2)

LEAD-FREE SOLDER

This product is manufactured using lead-free solder as a part of a movement within the consumer products industry at large to be environmentally responsible. Lead-free solder must be used in the servicing and repair of this product.

WARNING

This product is manufactured using lead free solder.

DO NOT USE LEAD BASED SOLDER TO REPAIR THIS PRODUCT !

The melting temperature of lead-free solder is higher than that of leaded solder by 86°F to 104°F (30°C to 40°C). Use of a soldering iron designed for lead-based solders to repair product made with lead-free solder may result in damage to the component and or PCB being soldered. Great care should be made to ensure high-quality soldering when servicing this product — especially when soldering large components, through-hole pins, and on PCBs — as the level of heat required to melt lead-free solder is high.

SAFETY NOTICE

SAFETY PRECAUTIONS

LEAKAGE CURRENT CHECK

The AC line cord of power supply connect to terminal. And plug the AC line cord of power supply into a 120V AC outlet. Use an AC voltmeter, having 5000 Ω per volt or more sensitivity.

Connect a 1500 Ω 10W resistor, paralleled by a 0.15 μ F 150V AC capacitor between a known good earth ground (water pipe, conduit, etc.) and all exposed metal parts of cabinet (screw heads etc.).

Measure the AC voltage across the 1500 Ω resistor. The test must be conducted with the AC switch on and then repeated with the AC switch off. The AC voltage indicated by the meter may not exceed 0.3V. A reading exceeding 0.3V indicates that a dangerous potential exists, the fault must be located and corrected. Repeat the above test with AC line reversed. NEVER RETURN A CAMERA TO THE CUSTOMER WITHOUT TAKING NECESSARY CORRECTIVE ACTION.

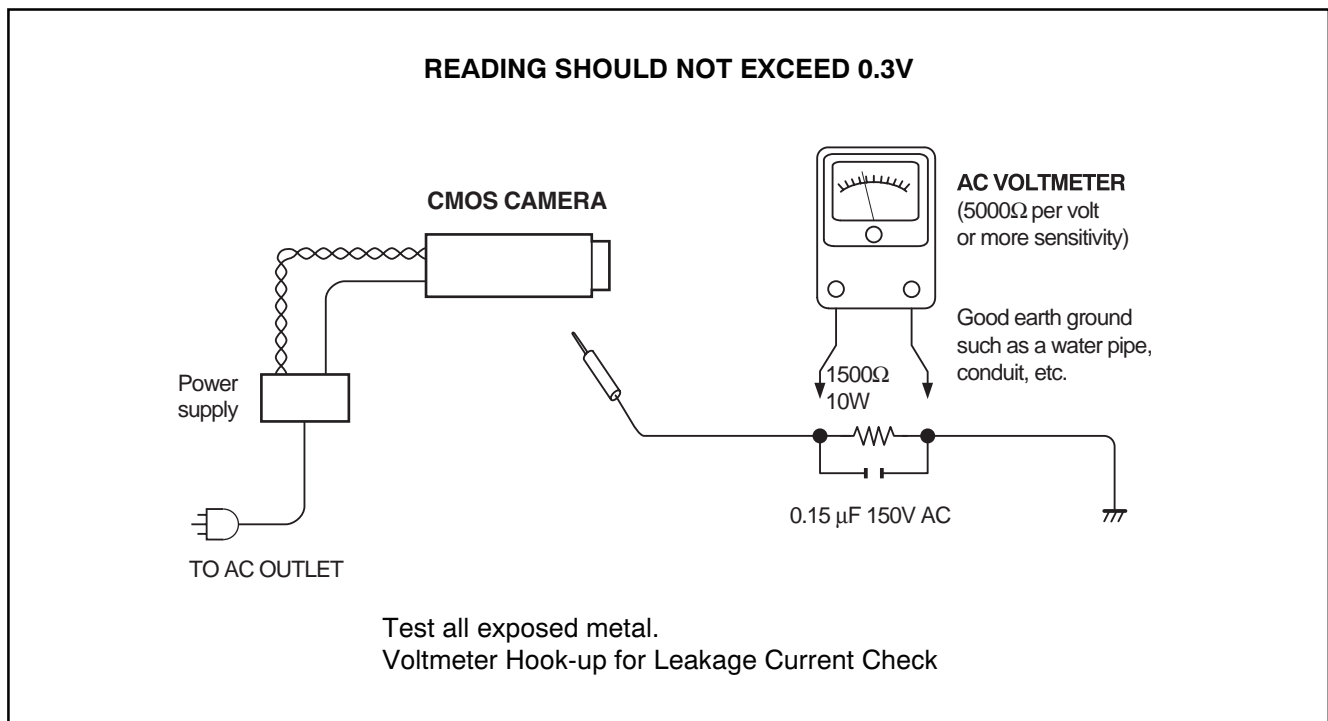

The lightning flash with arrowhead symbol, within an equilateral triangle, is intended to alert the user to the presence of uninsulated “dangerous voltage” within the product’s enclosure that may be of sufficient magnitude to constitute a risk of electric shock to persons.



The exclamation point within an equilateral triangle is intended to alert the user to the presence of important operating and maintenance (servicing) instructions in the literature accompanying the appliance.

CONTENTS

SECTION 1

GENERAL DESCRIPTION

1 CAUTION ON USE AND INSTALLATION	1-3	6 ITEMS CONTROLLED BY THE ON SCREEN DISPLAY	1-6
2 COMPONENTS	1-3	7 MODE SETTING BY THE ON SCREEN DISPLAY	1-7
3 NAMES AND FUNCTIONS	1-3	8 BEFORE MAKING SERVICE CALL	1-13
4 CONNECTION.....	1-4	9 SPECIFICATIONS	1-13
5 OPERATION.....	1-5	10 EXTERNAL APPEARANCE DIAGRAM	1-13

SECTION 5

SPECIFICATIONS

1. SPECIFICATIONS.....	5-1
------------------------	-----

SECTION 1 GENERAL DESCRIPTION

SAFETY PRECAUTIONS

Safety icons

This manual contains safety instructions that must be observed in order to avoid potential hazards that could result in personal injuries, damage to your equipment, or loss of data. These safety cautions have been classified according to the seriousness of the risk, and the icons highlight these instructions as follows:

- ▲ WARNING** Indicates a potentially hazardous situation which, if not avoided, could result in death or serious injury.
- ▲ CAUTION** Indicates a potentially hazardous situation which, if not avoided, may result in minor or moderate injury.
- CAUTION** Indicates a potentially hazardous situation which, if not avoided, may result in property damage.

CAUTION

Note the following instructions when installing.

- Do not cover the product with any material.
 - Do not place the product on any inflammable material such as a carpet or blanket.
 - Do not place the product in a confined space, as this may cause heat to build up inside the product.
- Failure to follow the above cautions may result in fire.

CAUTION

Do not place the product in direct sunshine and/or high temperature.
Temperature build up inside the product may result in fire.

▲ CAUTION

Avoid placing in humid, smoky, or dusty places.
This may result in fire and/or electrical shock.

▲ CAUTION

Do not point the lens directly at the sun and/or intensive light such as direct sunlight, etc.
Focusing of the light may result in eye injury and/or fire.

CAUTION

Ask your dealer to perform a periodical check and internal cleaning (approx. once every five years).
Dust inside the product may result in fire. For check and cleaning cost, please consult your dealer.

▲ WARNING

Stop operation immediately if any abnormality or defect occurs.
Use during an abnormal condition, such as emitting smoke, burning odors, getting extremely hot, damage from dropping, invasion of foreign objects, etc. may result in fire and/or electrical shock. Immediately disconnect the power source and contact your dealer.

▲ WARNING

Avoid installing in a shower room or a bathroom.
This may result in fire and/or electrical shock.

▲ WARNING

Do not operate in places where the product may get wet.
This may result in fire and/or electrical shock.

▲ WARNING

Do not repair, disassemble and/or modify by yourself.
This may result in fire and/or electrical shock. Always be sure to contact your dealer for internal repair, check and cleaning of the product.

▲ WARNING

Use the specified power supply.
Otherwise, fire or electrical shock may occur.

▲ WARNING

Do not place anything on top of the unit.
Foreign materials, such as metals or liquids, getting into the product may result in fire and/or electrical shock.

▲ WARNING

Do not put the product on an unstable, slanted or vibrating surface.
The product dropping or falling may result in serious injury.

▲ WARNING

Do not touch the product or any connection cables during a thunderstorm.
This may result in electrical shock.

Disclaimer

We disclaim any responsibility and shall be held harmless for any damages or losses incurred by the user in any of the following cases:

1. Fire, earthquake or any other act of God; acts by third parties; misuse by the user, whether intentional or accidental; use under extreme operating conditions.
2. Malfunction or non-function resulting in indirect, additional or consequential damages, including but not limited to loss of expected income and suspension of business activities.
3. Incorrect use not in compliance with instructions in this instruction manual.
4. Malfunctions resulting from disconnection to other equipment.
5. Repairs or modifications made by the user or caused to be made by the user and carried out by an unauthorized third party.
6. Notwithstanding the foregoing, Toshiba's liabilities shall not, in any circumstances, exceed the purchase price of the product.

Copyright and Right of Portrait

There may be a conflict with the Copyright Law and other laws when a customer uses, displays, distributes, or exhibits an image picked up by the camera without permission from the copyright holder. Please also note that transfer of an image or file covered by copyright is restricted to use within the scope permitted by the Copyright Law.

Protection of Personal Information

Images taken by the camera that reveal the likeness of an individual person may be considered personal information. To disclose, exhibit or transmit those images over the internet or otherwise, consent of the person may be required.

Limitation of Usage

The product is not designed for any "critical applications." "Critical applications" means life support systems, exhaust or smoke extraction applications, medical applications, commercial aviation, mass transit applications, military applications, homeland security applications, nuclear facilities or systems or any other applications where product failure could lead to injury to persons or loss of life or catastrophic property damage. Accordingly, [Toshiba/TAIS] disclaims any and all liability arising out of the use of the product in any critical applications.

TABLE OF CONTENTS

1. CAUTIONS ON USE AND INSTALLATION	6
2. COMPONENTS	6
3. NAMES AND FUNCTIONS	7
4. CONNECTION	8
4.1 Standard Connection	8
4.2 Cautions on Connection	8
4.3 Connection on Rear Panel	9
4.3A Connector Pin Assignments	9
5. OPERATION	10
5.1 White Balance	10
5.2 Gain	12
6. ITEMS CONTROLLED BY THE ON SCREEN DISPLAY	13
7. MODE SETTING BY THE ON SCREEN DISPLAY	14
7.1 Using the Menus	14
7.2 Scene File	14
7.3 Menus	15
(1) SHUTTER (Electronic shutter)	15
(1.1) Changing the setting in AUTO mode	15
(1.2) Changing the setting in MANUAL mode	17
(1.3) Changing the setting in SS (Synchro Scan) mode	17
(2) GAIN (Video gain)	18
(2.1) Changing gain in MANUAL mode	18
(3) WHT BAL (White Balance)	18
(3.1) Changing the setting in AWB (Automatic White Balance) mode	18
(3.2) Changing the setting in ATW (Automatic Tracking White balance) mode	20
(3.3) Changing gain in MANUAL mode	21
(4) PROCESS	22
(4.1) Changing gamma correction ON/OFF	22
(4.2) Changing gamma correction level	22
(4.3) Changing detail (outline) gain	23
(4.4) Changing DTL B. FREQ (detail boost frequency)	23
(4.5) Changing master pedestal	23
(5) MATRIX (Matrix color correction)	24
(5.1) Changing Matrix color correction ON/OFF	24
(5.2) Changing MATRIX setting	24

(6) OPTION	25
(6.1) Changing RS-232C baud rate	25
(7) Returning to factory settings	25
8. BEFORE MAKING SERVICE CALL	26
9. SPECIFICATIONS	26
10. EXTERNAL APPEARANCE DIAGRAM	27

1. CAUTIONS ON USE AND INSTALLATION

- **Handling the unit.**
Do not drop, jolt, or vibrate, as this may result in damage to the unit. This may cause problems. Treat the camera cables carefully to prevent cable problems, such as breaks in the cable and loose connections.
- **Install the camera in a location free from noise.**
If the camera or the cables are located near power utility lines or a TV, etc. undesirable noise may appear on the screen. In such a case, try to change the location of the camera or the cable wiring.
- **Operating ambient temperature and humidity.**
Do not use the camera in places where temperature and humidity exceed the specifications. Picture quality will deteriorate and internal parts may be damaged.
Be particularly careful when using in places exposed to direct sunlight. When shooting in hot places, depending on the conditions of the object and the camera (for example when the gain is increased), noise in the form of vertical strips or white dots may occur. This is not a malfunction.
- **When not using the camera for extended periods of time.**
Switch the control unit off and disconnect the power supply.
- **Avoid using or storing the camera in the following places:**
Places filled with highly flammable gas.
Places near gasoline, benzene, or paint thinner.
Places subject to strong vibration.
Places containing chemicals (such as pesticides), rubber or vinyl products for extended periods of time.
- **Do not shoot intense light.**
When intense light enters, vertical stripes or transverse bands may appear on the screen. This is not a malfunction. Ghosts may occur when there is an intense light near the object. In this case, change the shooting angle.
- **Moire**
A moire pattern is an interference pattern generated when two repetitive line patterns overlap. This is not a malfunction. Eliminating the repetitive line patterns, or aligning the two patterns, will eliminate the moire.
- **Handling of the protection cap.**
Keep the protection cap away from children as they may pose a choking hazard. The protection cap protects the image sensing plane when the lens is removed from the camera head, do not discard.
- **When cleaning the camera.**
Unplug the power source before cleaning. Clean with a soft dry cloth only. Do not use any chemicals or chemically treated cloths. Chemicals may damage coatings, printing or the paint work. When cleaning the lens, use lens cleaning paper.
- **Installation without a tripod.**
Before installing the camera, make sure that the location can withstand the total weight of the camera.
If this is not the case, reinforce the area to prevent the unit from dropping, which may result in damage to the unit or personal injury.
- **This camera is for indoor use only.**

2. COMPONENTS

(1) Camera	1
(2) Accessories	
(a) Instruction manual	1
(b) Tripod mount	1
(c) Screws (for the tripod mount)	4

3. NAMES AND FUNCTIONS

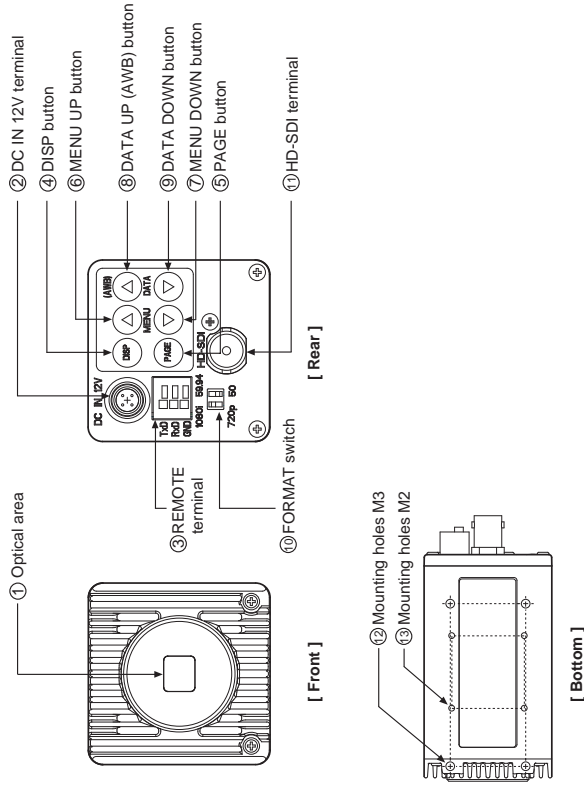

- ① Optical area
 - ② DC IN 12V terminal
 - ③ REMOTE terminal
 - ④ DISP button
 - ⑤ PAGE button
 - ⑥ MENU UP button
 - ⑦ MENU DOWN button
 - ⑧ DATA UP (AWB) button
 - ⑨ DATA DOWN button
 - ⑩ FORMAT switch
 - (1) Effective scanning lines
 - (2) Vertical frequency
 - ⑩ HD-SDI terminal
 - ⑫ Mounting holes M3
 - ⑬ Mounting holes M2
- The protection cap is attached on the lens mount portion. After removing the cap, mount the lens. Be careful not to scratch or touch the optical area.
 Accepts a DC power input (12V).
 To connect to a RS-232C device for remote control of the camera.
 Used when switching the display.
 Used when switching to the menu and when selecting the menu.
 Select the function to be confirmed or changed on the menu.
 Select the function to be confirmed or changed on the menu.
 Changes the value of the function selected by the MENU (UP/DOWN) button. (Also used when performing AWB.)
 Changes the value of the function selected by the MENU (UP/DOWN) button.
 Switches between 1080i and 720p. (Factory default setting: 1080i)
 * Switching the effective scanning between 1080i and 720p changes the angle of view on a monitor.
 Switches between 59.94 Hz and 50 Hz. (Factory default setting: 59.94 Hz)
 Outputs a serial digital signal. (BNC connector)
 Used to attach the camera to a mount.
 Used to attach the camera to a mount. When using a tripod, attach the supplied tripod mount to these holes.

4. CONNECTION

4. 1 Standard Connection

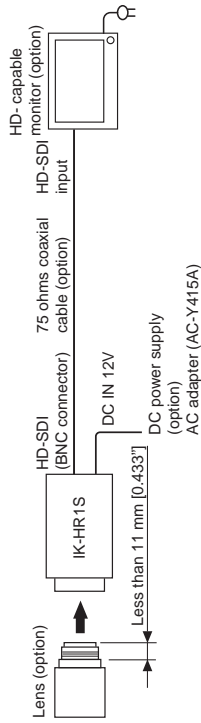

4. 2 Cautions on Connection

- When connecting the camera cables, be sure to turn off the CMOS color camera and any other equipment connected to it.
- For DC supply connecting to DC IN 12V terminal, when not using AC adapter: AC-Y415A (not supplied), use UL listed and/or CSA approved ungrounded type AC adapter with the specifications described below. Please purchase connectors separately.

Power supply voltage	: 12V DC \pm 10%
Current rating	: More than 830mA
Ripple voltage	: Less than 50mV (p-p)
Connector	: HR10A-7P-4S by HIROSE electronics Co. Ltd
	Pins 1, 2 : 12V
	Pins 3, 4 : GND
- We suggest using a C mount mega pixel lens. When using other lenses, the best performance of this camera may not be obtained. (For example, low resolution may occur, focus may be lost through the range of a zoom lens, and flare, ghosting may occur.) Furthermore, in order to avoid damaging the mounting portion of the camera head, use a lens which has projection dimension from the mounting base of less than 0.433" (11mm.)
- Please use a good quality, low resistance cable for the HD-SDI terminal.

4. 3 Connection on Rear Panel

There are DC IN 12V, REMOTE terminals and HD-SDI terminal (BNC connector) for basic connection on the rear panel. Please use them as needed.

Rear panel view

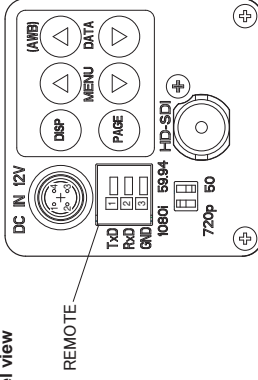

4. 3A Connector Pin Assignments

DC IN 12V terminal	REMOTE terminal
1 +12V	1 TXD
2 +12V	2 RXD
3 GND	3 GND
4 GND	

* For connecting to the REMOTE terminal, use a shielded cable. Connect the cable correctly or damage may occur to the camera.

5. OPERATION

- ① Refer to the item "4. CONNECTION", and connect the equipment correctly.
- ② Turn on the connected equipment and the camera.
- ③ Aim the lens at the object, adjust the lens iris adjustment, focus adjustment, etc.
- ④ Refer to the item "5.1 White Balance", make the adjustment.
- ⑤ Refer to the items "5.2 Gain", "7. MODE SETTING BY THE ON SCREEN DISPLAY", select the necessary items.

5. 1 White Balance

For white balance adjustment of this unit, ATW (Automatic Tracking White balance), AWB (Automatic White Balance) and MANUAL (Manual white balance) adjustments are provided. Refer to the item "7.3 (3) WHT BAL (White Balance)", select the desired mode.

	ATW (Automatic Tracking White Balance)	AWB (Automatic White Balance)	MANUAL (Manual White Balance)
Outline	The camera measures the object color temperature and adjusts the white balance automatically.	Adjust white balance by displaying the white object inside the area set by AWB menu and pressing the [DATA UP] button.	Adjust the white balance manually using the WHT BAL menu while shooting the white object.
Features	Tracks variations of color temperature and adjusts white balance automatically.	Measurement accuracy is higher than ATW. This mode is effective when shooting under less variations of color temperature.	Artificial white balance setting. The manual adjustment is most effective under shooting conditions with no color temperature variation.
Notes	If illumination is low, white balance may not be corrected.		Adjustment is performed by confirming with a monitor.

(1) AWB(Automatic White Balance)

- ① Set the MODE to AWB on the WHT BAL menu.
Perform the C.TEMP (color temperature conversion) setting, if necessary.
(Refer to the item "7.3 (3) WHT BAL (White Balance)".)
 - ③ 3200K: Appropriate for indoor shooting.
 - ④ 5600K: Appropriate for outdoor shooting.
- ② If the color bar pattern is displayed on the screen or if the index menu/menu is displayed, press the [DISP] button to disable the color bar pattern or the character display on the menu.
- ③ Shoot a known white object entirely in the area set by the AWB menu (refer to the item "7.3 (3) (3.1) (d) Confirming the contents of the zone area selected by AWB") and press [DATA UP] button for approx. 1 second.
- ④ The character AWB blinks on the screen when the AWB starts.
- ⑤ The character AWB stops blinking when the AWB finishes, and the result is displayed for approx. 1 second.

Display	Meaning
AWB OK	Automatic white balance adjustment finished correctly.
AWB NG LEVEL LOW	Automatic white balance adjustment cannot be performed because the video level is too low. Adjust the video level by increasing the illumination or opening the lens iris.
AWB NG LEVEL HIGH	Automatic white balance adjustment cannot be performed because the video level is too high. Adjust the video level by decreasing the illumination or closing the lens iris.
AWB NG C. TEMP LOW	Automatic white balance adjustment cannot be performed because the color temperature is too low. If the C.TEMP is set to 5600K, set to 3200K. If the message appears with the C.TEMP set to 3200K, change the illumination or use a color temperature conversion filter.
AWB NG C. TEMP HIGH	Automatic white balance adjustment cannot be performed because the color temperature is too high. If the C.TEMP is set to 3200K, set to 5600K. If the message appears with the C.TEMP set to 5600K, change the illumination or use the color temperature conversion filter.
AWB NG	Automatic white balance adjustment cannot be performed for other reasons. Such as no white area is included in an object, etc.

(2) MANUAL(Manual white balance)

- ① Set the MODE to MANUAL on the WHT BAL menu.
(Refer to the item "7.3 (3) WHT BAL (White Balance)".)
- ② Shoot a known white object, set the white balance by adjusting the levels of R GAIN and B GAIN on the menu, confirming with a monitor or a vector scope.
(Refer to the item "7.3 (3) (3.3) Changing gain in MANUAL mode".)

5. 2 Gain

When the image is dark even if the lens iris is open, change the gain (video gain) to get the desired video level. For gain adjustment of the unit, MANUAL (Manual), OFF (0 dB) modes are provided. Select the mode on the GAIN menu. (Refer to the item "7.3 (2) GAIN (Video gain)".)

(1) MANUAL (Manual gain)

Gain adjustment is performed on the GAIN menu. The adjustment range is from 0 to 18dB in 1dB steps. (Refer to the item "7.3 (2) (2-1) Changing gain in MANUAL mode".)

(2) OFF

Gain is fixed at 0 dB.

Note:

White, red, green, or blue dots may occur when the gain is increased. This is not a malfunction, just certain characteristics of the CMOS sensor becoming more visible.

6. ITEMS CONTROLLED BY THE ON SCREEN DISPLAY

Item	Available selections	Preset value (Factory setting)
Electronic shutter	AUTO, MANUAL, SS -100 — 0 — 100 00 : 10 — 05 : 05 — 10 : 00 1 — 10 — 20 PRESET A, PRESET B, PRESET C, PRESET D, PRESET E OFF, 1/1000s, 1/125s, 1/250s, 1/500s, 1/1000s, 1/2000s, 1/4000s 15/1125H — 1123/1125H (1080i setting) 10/750H — 748/750H (720p setting)	MANUAL 0 05 : 05 10 PRESET A
Gain	MANUAL, OFF 0dB — 18dB AWB, ATW, MANUAL 3200K, 5600K -10 — 0 — 10 -10 — 0 — 10 PRESET A, PRESET B, PRESET C, PRESET D, PRESET E	1123/1125H 748/750H 0dB AWB 3200K 0 0 PRESET A
White balance	ATW R PAINT -10 — 0 — 10 ATW B PAINT -10 — 0 — 10 MANUAL R GAIN -100 — 0 — 100 MANUAL B GAIN -100 — 0 — 100 Gamma correction ON, OFF Gamma correction level -10 — 0 — 10 Detail gain -7 — 0 — 7 Detail boost frequency HIGH, NORMAL, LOW Master pedestal -128 — 0 — 127 Color correction ON/OFF ON, OFF	0 0 0 0 0 0 ON 0 0 HIGH 0 ON
Process	R hue -15 — 0 — 15 R gain -15 — 0 — 15 G hue -15 — 0 — 15 G gain -15 — 0 — 15 B hue -15 — 0 — 15 B gain -15 — 0 — 15 Ye hue -15 — 0 — 15 Ye gain -15 — 0 — 15 Cy hue -15 — 0 — 15 Cy gain -15 — 0 — 15 Mg hue -15 — 0 — 15 Mg gain -15 — 0 — 15	0 0 0 0 0 0 0 0 0 0 0 0 0 0 0 0 0 0 0 0
Matrix color correction	RS-232C baud rate 9600bps, 19200bps	9600bps
Option		

*1: 1/60 s (69.94 Hz setting), or 1/50 s (60 Hz setting)

*2: Gain 0 dB

7. MODE SETTING BY THE ON SCREEN DISPLAY

Various settings can be controlled on the unit by using the on screen menu displayed on the monitor. The contents once set are memorized in the scene files (A, B, C, D, E) selected, so if the power turns off, it is unnecessary to set the values again when using the unit next time. When the setting is performed, select the menu of the item to be set.

7. 1 Using the Menu

When the unit is powered on, the normal screen showing only the video signal appears. Change the output to each screen (video signal output, color bar screen, index menu, and menu) by using the [DISP], [PAGE], [MENU UP], [MENU DOWN], [DATA UP], and [DATA DOWN] buttons.

* A menu is selected when pushing the [PAGE] button after moving the "→" on the screen by the [MENU UP], [MENU DOWN] button while the Index menu is displayed.

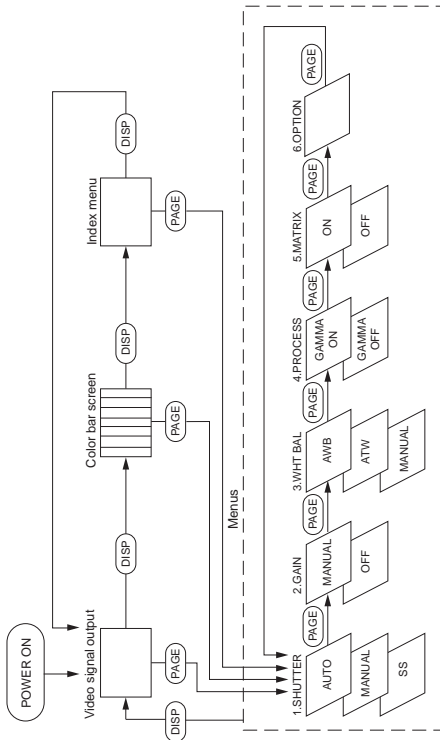

7. 2 Scene File

Five scene files (A, B, C, D, E) are available as user memories for this unit. These are chosen depending on shooting conditions. By pressing [DATA UP], [DATA DOWN] buttons while [DISP] button is pressed and the index menu is displayed, the camera operation is changed immediately from the currently selected scene file to the next.



Note:
Scene file does not contain the data of set "OPTION."
(Refer to the item "7.3 Menu" (6) "OPTION" for the "OPTION" setting.)

7. 3 Menu

Select the menu to change the setting by referring to the item "7.1 Using the Menu".
When the [MENU UP], [MENU DOWN] buttons are pressed, the "→" on the screen moves up and down. Move the "→" to the item whose setting you wish to change.

(1) SHUTTER (Electronic shutter)

The electronic shutter has three modes: AUTO, MANUAL, SS(Synchro Scan). Press the "Page" button to enter the Shutter Page. Use the "Data Up/Down" buttons to select the Shutter Mode.



AUTO : The exposure time is controlled automatically to obtain the video level set.
MANUAL : It is possible to select the exposure time from eight speed settings:
OFF (1/60s : 59.94 Hz setting, 1/50s : 50 Hz setting), 1/100s, 1/250s, 1/500s, 1/1000s, 1/2000s, 1/4000s.
SS : Shutter speed can be set by the horizontal scanning time (1H) unit.

Note:

- When setting a rapid shutter speed, sensitivity degrades according to the speed. When a discharging light such as fluorescent lamp, etc. is used for the illumination, the flicker may be large.
- When an object is moving rapidly, the monitor may display the image distorted and/or blurred. This is not a malfunction, just certain character of the rolling shutter system.
- When the shutter speed setting is high, the hue may change depending on shooting conditions or objects.

(1. 1) Changing the setting in AUTO mode

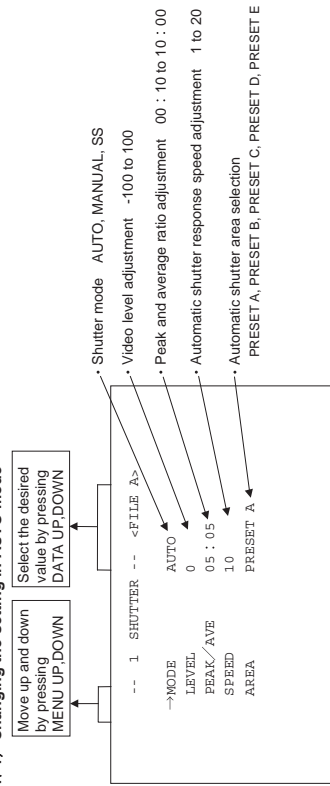

(a) Changing the video level in the automatic shutter mode

- Move the "→" to LEVEL by pressing [MENU UP], [MENU DOWN] buttons.
- Select the video level by pressing [DATA UP], [DATA DOWN] buttons.

The value increases by pressing [DATA UP]
-100 ↔ 0 ↔ 100
The value increases by pressing [DATA DOWN]

(b) Changing the automatic shutter detection (ratio between peak and average value)

- ① Move the "→" to PEAK/AVE by pressing [MENU UP], [MENU DOWN] buttons.
- ② Select the ratio between peak and average value by pressing [DATA UP], [DATA DOWN] buttons.

(Peak/Average)

The peak value increases by pressing [DATA UP]

00:10 ↔ 05:05 ↔ 10:00

The peak value decreases by pressing [DATA DOWN]

(c) Changing the automatic shutter response speed

- ① Move the "→" to SPEED by pressing [MENU UP], [MENU DOWN] buttons.
- ② Select the response speed by pressing [DATA UP], [DATA DOWN] buttons.

The response speed becomes faster by pressing [DATA UP]

1 ↔ 10 ↔ 20

The response speed becomes slower by pressing [DATA DOWN]

(d) Changing the automatic shutter zone area

- ① Move the "→" to AREA by pressing [MENU UP], [MENU DOWN] buttons.
- ② Select the measurement light area by pressing [DATA UP], [DATA DOWN] buttons.



The picture area is shown by the shaded area on the screen that is divided into 64 parts.

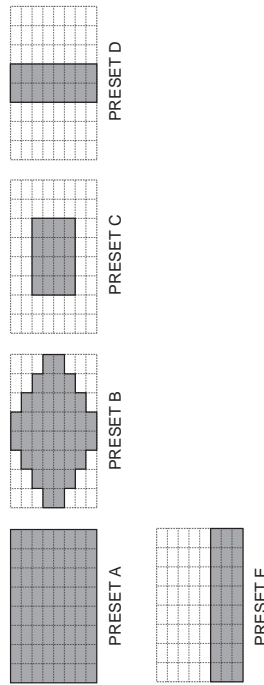

(1. 2) Changing the setting in MANUAL mode

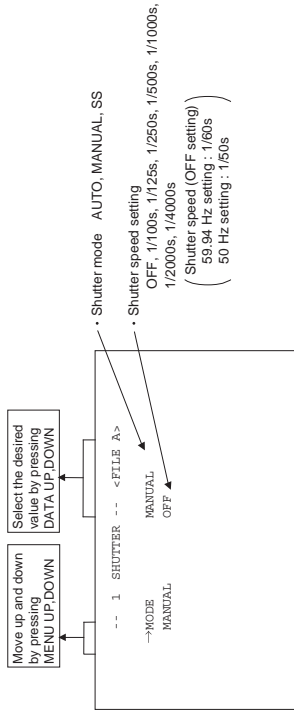

(a) Changing the shutter speed

- ① Move the "→" to MANU by pressing [MENU UP], [MENU DOWN] buttons.
- ② Select the shutter speed by pressing [DATA UP], [DATA DOWN] buttons.

OFF ↔ 1/100s ↔ 1/125s ↔ 1/250s ↔ 1/500s ↔ 1/1000s ↔ 1/2000s ↔ 1/4000s
[DATA UP]
[DATA DOWN]

Note:

- It can be set every effective scanning line. (1080i / 720p)
- These figures of shutter speed are approximate. The accurate shutter speed is calculated using the following mathematical formula.

$$\text{Shutter speed (s)} = \frac{1}{67433 \text{ (Hz)} \times n} \quad (n : 15 \text{ to } 1123 \text{ (integral number)}) \quad (1080i / 59.94 \text{ Hz setting})$$

$$\frac{1}{56250 \text{ (Hz)} \times n} \quad (n : 15 \text{ to } 1123 \text{ (integral number)}) \quad (1080i / 50 \text{ Hz setting})$$

$$\frac{1}{44955 \text{ (Hz)} \times n} \quad (n : 10 \text{ to } 748 \text{ (integral number)}) \quad (720p / 59.94 \text{ Hz setting})$$

$$\frac{1}{37500 \text{ (Hz)} \times n} \quad (n : 10 \text{ to } 748 \text{ (integral number)}) \quad (720p / 50 \text{ Hz setting})$$

(1. 3) Changing the setting in SS (Synchro Scan) mode

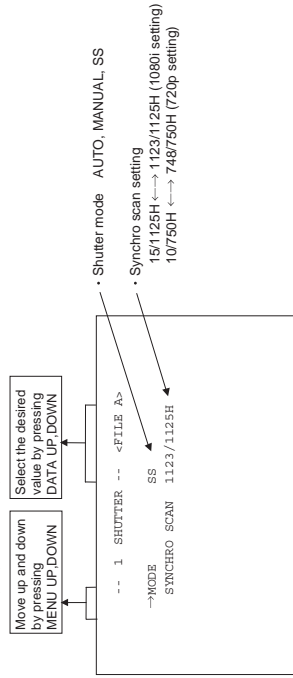

(a) Changing the shutter speed setting

- ① Move the "→" to SYNCHRO SCAN by pressing [MENU UP], [MENU DOWN] buttons.
- ② Select the shutter speed by pressing [DATA UP], [DATA DOWN] buttons.

[DATA UP]
15/1125H ↔ 1123/1125H (1080i setting)
10/750H ↔ 748/750H (720p setting)
[DATA DOWN]

(2) GAIN (Video gain)

GAIN has two modes: MANUAL, OFF.

Move the "→" to MODE, press the [DATA UP], [DATA DOWN], and select one of the two modes : MANUAL, OFF. In the OFF mode, gain is fixed to 0dB.

(2. 1) Changing gain in MANUAL mode

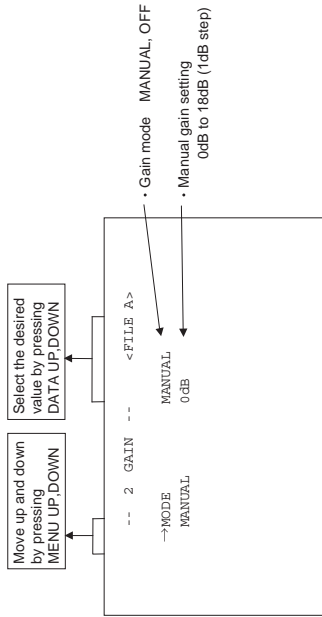

- 1 Move the "→" to MANUAL by pressing [MENU UP], [MENU DOWN] buttons.
- 2 Select the desired value of manual gain by pressing [DATA UP], [DATA DOWN] buttons.

0dB ↔ 18dB
[DATA UP]
[DATA DOWN]

(3) WHT BAL(White Balance)

The WHT BAL has three modes; AWB, ATW, MANUAL.

Move the "→" to MODE, press the [DATA UP], [DATA DOWN], and select one of the three modes : AWB, ATW, MANUAL.

(3. 1) Changing the setting in AWB(Automatic White Balance) mode

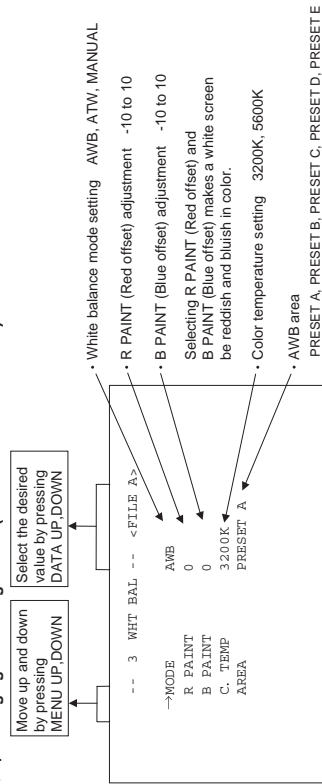

- 18 -

(a) Changing R PAINT

- 1 Move the "→" to R PAINT by pressing [MENU UP], [MENU DOWN] buttons.
- 2 Select the desired value of red paint by pressing [DATA UP], [DATA DOWN] buttons.

[DATA UP] → Red is increased.
-10 ↔ 0 ↔ 10
Red is decreased. ← [DATA DOWN]

(b) Changing B PAINT

- 1 Move the "→" to B PAINT by pressing [MENU UP], [MENU DOWN] buttons.
- 2 Select the desired value of blue paint by pressing [DATA UP], [DATA DOWN] buttons.

[DATA UP] → Blue is increased.
-10 ↔ 0 ↔ 10
Blue is decreased. ← [DATA DOWN]

(c) Changing color temperature setting

- 1 Move the "→" to C.TEMP by pressing [MENU UP], [MENU DOWN] buttons.
- 2 Select either 3200K or 5600K by pressing [DATA UP], [DATA DOWN] buttons.

(d) Confirming the contents of the zone area selected by AWB

- 1 Move the "→" to AREA DISP by pressing [MENU UP], [MENU DOWN] buttons.
- 2 Select the desired area by pressing [DATA UP], [DATA DOWN] buttons.

The picture area is shown by the shaded area on the screen that is divided into 64 parts.

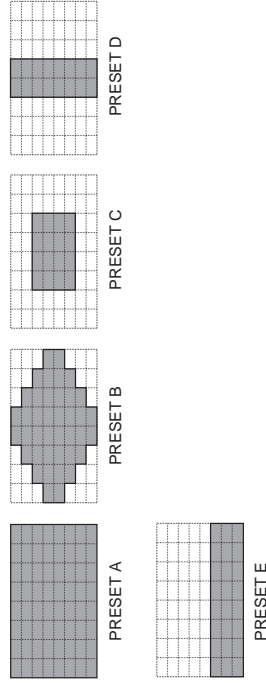

- 19 -

(3. 2) Changing the setting in ATW(Automatic Tracking White balance) mode

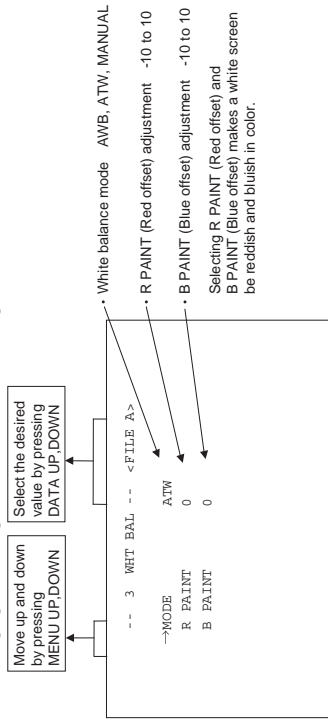

(a) Changing R PAINT (Red offset)

- 1 Move the "→" to R PAINT by pressing [MENU UP], [MENU DOWN] buttons.
- 2 Select the desired value of red paint by pressing [DATA UP], [DATA DOWN] buttons.

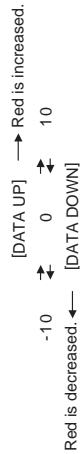

(b) Changing B PAINT (Blue offset)

- 1 Move the "→" to B PAINT by pressing [MENU UP], [MENU DOWN] buttons.
- 2 Select the desired value of blue paint by pressing [DATA UP], [DATA DOWN] buttons.

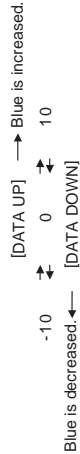

(3. 3) Changing gain in MANUAL mode

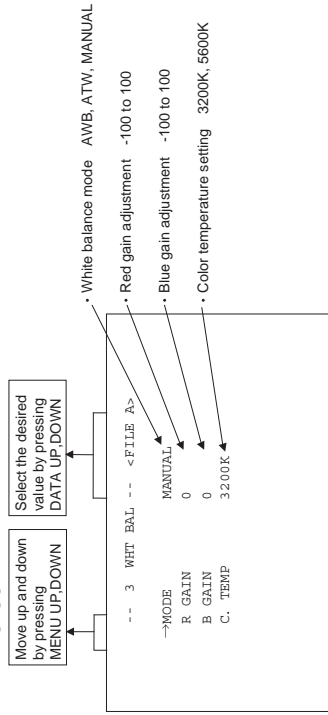

(a) Changing the red gain

- 1 Move the "→" to R GAIN by pressing [MENU UP], [MENU DOWN] buttons.
- 2 Select the desired value of red gain by pressing [DATA UP], [DATA DOWN] buttons.

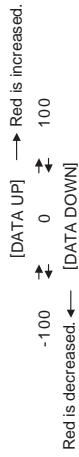

(b) Changing the blue gain

- 1 Move the "→" to B GAIN by pressing [MENU UP], [MENU DOWN] buttons.
- 2 Select the desired value of blue gain by pressing [DATA UP], [DATA DOWN] buttons.



(c) Changing color temperature setting

- 1 Move the "→" to C. TEMP by pressing [MENU UP], [MENU DOWN] buttons.
- 2 Select either 3200K or 5600K by pressing [DATA UP], [DATA DOWN] buttons.

(4. 1) PROCESS

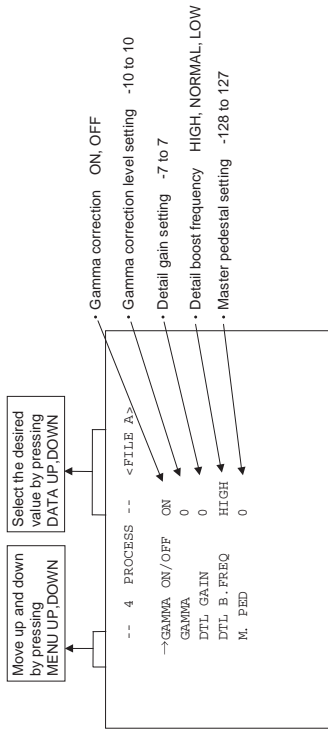

(4. 1) Changing gamma correction ON/OFF

- 1 Move the "→" to GAMMA ON/OFF by pressing [MENU UP], [MENU DOWN] buttons.
- 2 Select either ON or OFF by pressing [DATA UP], [DATA DOWN] buttons.

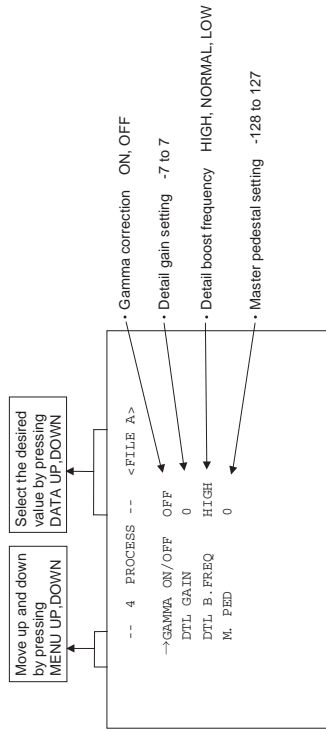

Menu when GAMMA OFF is selected.

(4. 2) Changing gamma correction level

- 1 Move the "→" to GAMMA by pressing [MENU UP], [MENU DOWN] buttons.
- 2 Select the desired value of gamma correction level by pressing [DATA UP], [DATA DOWN] buttons.



* When OFF is selected in GAMMA ON/OFF selection line, the gamma correction level cannot be changed.

(4. 3) Changing detail (outline) gain

- 1 Move the "→" to DTL GAIN by pressing [MENU UP], [MENU DOWN] buttons.
- 2 Select the desired value of the detail gain by pressing [DATA UP], [DATA DOWN] buttons.

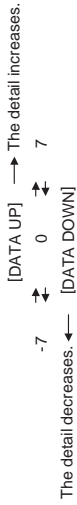

(4. 4) Changing DTL B. FREQ (detail boost frequency)

This item sets the thickness of the outline.

- 1 Move the "→" to DTL B. FREQ by pressing [MENU UP], [MENU DOWN] buttons.
- 2 Select the detail boost frequency by pressing [DATA UP], [DATA DOWN] buttons.



(4. 5) Changing master pedestal

- 1 Move the "→" to M. PED by pressing [MENU UP], [MENU DOWN] buttons.
- 2 Select the desired value of the master pedestal by pressing [DATA UP], [DATA DOWN] buttons.



(5) MATRIX(Matrix color correction)

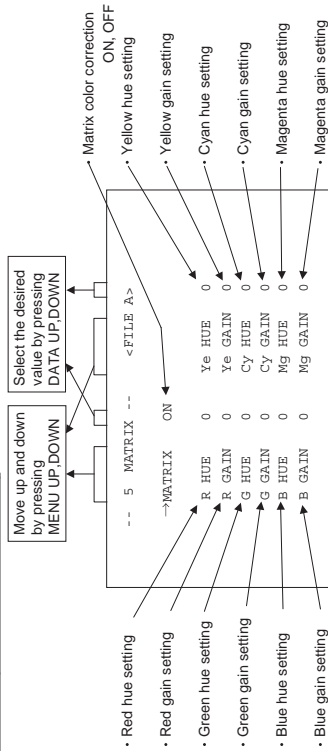

(5. 1) Changing Matrix color correction ON/OFF

- ① Move the "←" to MATRIX by pressing [MENU UP], [MENU DOWN] buttons.
- ② Select either ON or OFF by pressing [DATA UP], [DATA DOWN] buttons.

(5. 2) Changing MATRIX setting

- ① Move the "←" to the desired item by pressing [MENU UP], [MENU DOWN] buttons.
- ② Select the desired value of color by pressing [DATA UP], [DATA DOWN] buttons.



* When matrix color correction is set to OFF, the color cannot be adjusted.

(6) OPTION

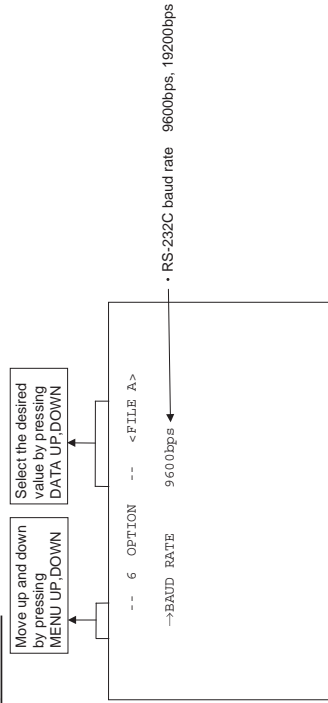

(6. 1) Changing RS-232C baud rate

- ① Move the "←" to BAUD RATE by pressing [MENU UP], [MENU DOWN] buttons.
- ② Select either 9600bps or 19200bps by pressing [DATA UP], [DATA DOWN] buttons.

(7) Returning to factory settings

The current setting can be returned to the factory default status (preset status).

- (1) If the color bar pattern or characters are displayed on the screen, press the [DISP] button to disable the color bar pattern and character display.
- (2) Press [MENU DOWN] and [DATA DOWN] buttons simultaneously for approx. 1 second.
- (3) The preset operation starts. When the preset operation finishes, the character PRESET OK is displayed for approx. 1 second.

* Only the one scene file that is selected will be returned to the factory default status when this action is performed. To return other scene files to the factory default status, select the desired scene file and perform this function again.

8. BEFORE MAKING SERVICE CALL

Symptom	Items to be checked
No picture	<ul style="list-style-type: none"> Is power supplied correctly? Is the lens iris adjusted correctly? Are the camera and video cables connected correctly? Is the shutter mode set correctly? Is the monitor on, and in working condition? Can the monitor (that you are using) accept the HD-SDI signal coming out of the camera?
Poor color	<ul style="list-style-type: none"> Is the monitor adjusted correctly? Is the white balance of the camera adjusted correctly? (in modes other than automatic tracking) Is the matrix color correction set correctly? Is the illumination sufficient?

9. SPECIFICATIONS

Image sensor	1/3 inch color CMOS sensor (Rolling shutter)
Output pixels	Horizontal : 1920, Vertical : 1080 (max)
Signal system	1080/59.94i, 1080/50i, 720/59.94p, 720/50p
Scanning system	Progressive
Scan frequency	Horizontal : 33.716 kHz, Vertical : 59.94 Hz (1080/59.94i setting) Horizontal : 28.125 kHz, Vertical : 50 Hz (1080/50i setting) Horizontal : 44.955 kHz, Vertical : 59.94 Hz (720/59.94p setting) Horizontal : 37.500 kHz, Vertical : 50 Hz (720/50p setting)
Sensitivity	F 4 standard (2000 lx, 3000K)
Minimum illumination	8 lx standard (50 IRE, F1.4, gain +18 dB, gamma setting ON (setting value 0), 3000 K)
Output signal	HD-SDI (SMPTE292M), 0.8 V (p-p) standard 75 ohms unbalanced BNC connector
Sync system	Internal
White balance	ATW (Automatic tracing white balance), AWB (Automatic white balance), MANUAL (Manual)
Gain	MANUAL (Manual), OFF (0 dB)
Scene file	A, B, C, D, E
Remote control	Serial data interface (RS-232C)
Lens mount	C mount
Power supply	12V DC±10%
Power consumption	Approx. 3.5 W
Weight	Approx. 150 g (0.33 lbs)
External dimension	44(W) x 44(H) x 78(D) mm (1.73"(W) x 1.73"(H) x 3.07"(D)) (excluding protrusions)
Operating temperature	0 °C to 40 °C (32 °F to 104 °F)
Operating humidity	Less than 90% (non condensing)

● Design and specifications are subject to change without notice.

10. EXTERNAL APPEARANCE DIAGRAM

Camera

Unit : mm [inch]

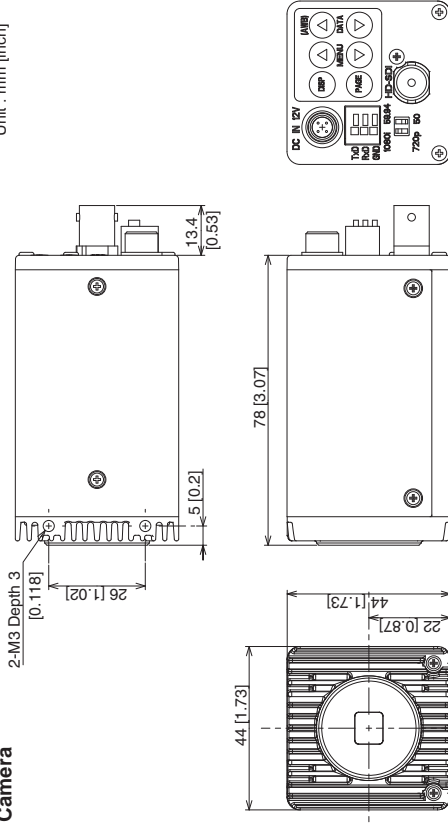

Tripod mount

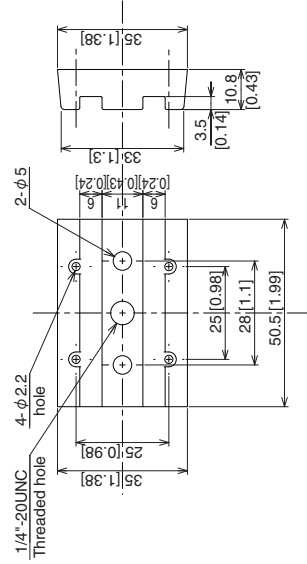

SECTION 5 SPECIFICATIONS

1. SPECIFICATIONS

Image sensor	1/3 inch color CMOS sensor (Rolling shutter)
Output pixels	Horizontal : 1920, Vertical : 1080 (max)
Signal system	1080/59.94i, 1080/50i, 720/59.94p, 720/50p
Scanning system	Progressive
Scan frequency	Horizontal : 33.716 kHz, Vertical : 59.94 Hz (1080/59.94i setting) Horizontal : 28.125 kHz, Vertical : 50 Hz (1080/50i setting) Horizontal : 44.955 kHz, Vertical : 59.94 Hz (720/59.94p setting) Horizontal : 37.500 kHz, Vertical : 50 Hz (720/50p setting)
Sensitivity	F 4 standard (2000 lx, 3000K)
Minimum illumination	8 lx standard (50 IRE, F1.4, gain + 18 dB, gamma setting ON (setting value 0), 3000 K)
Output signal	HD-SDI (SMPTE292M), 0.8 V (p-p) standard 75 ohms unbalanced BNC connector
Sync system	Internal
White balance	ATW (Automatic tracing white balance), AWB (Automatic white balance), MANUAL (Manual)
Gain	MANUAL (Manual), OFF (0 dB)
Scene file	A, B, C, D, E
Remote control	Serial data interface (RS-232C)
Lens mount	C mount
Power supply	12V DC±10%
Power consumption	Approx. 3.5 W
Weight	Approx. 150 g (0.33 lbs)
External dimension	44(W) × 44(H) × 78(D) mm (1.73"(W) × 1.73"(H) × 3.07"(D)) (excluding protrusions)
Operating temperature	0 °C to 40 °C (32° F to 104° F)
Operating humidity	Less than 90% (non condensing)

● Design and specifications are subject to change without notice.

TOSHIBA CORPORATION
1-1, SHIBAURA 1-CHOME, MINATO-KU, TOKYO 105-8001, JAPAN